

Keypad instructions continued

- ❑ RJ45 leads are then connected from the first OUT to the next CRE2801 IN socket & so on.
- ❑ On the side of the Driver set the address on the DIP switches to the required DMX Address 1 (see back page). All the DIPsw10's must all be set to OFF, until the last CRE2801 when it must be set to ON
- ❑ Connect mains lead (if not already attached) and power on unit.
- ❑ Please see diagram 2(separate sheet)for keypad



COLOUR CONTROL 3 From a Remote DMX programmer.

- ❑ Ensure the unit is not powered during installation (i.e. disconnect unit from mains).
- ❑ From the DMX Lighting Programmer connect to the first CRE2801 DMX RJ45 IN socket, see Diagram 3 (separate sheet)
- ❑ Set the desired DMX addresses on each CRE2801. See example Address 11, on back page. DIPsw10 must always be set to OFF until the last one, this must be set to ON (terminate)
- ❑ See also DMX Addressing (back page)
- ❑ Connect mains lead (if not already attached) and power on unit.

COLOUR CONTROL 4 SINGLE COLOUR

- ❑ See Diagram 4 (separate sheet) for wiring options using CRE2801 (max 36 led's,12 per channel) & CRE2802/12 (max 12 led's)
- ❑ Ensure the unit is not powered during installation (i.e. disconnect unit from mains).
- ❑ On the CRE2801 set the dip switches to 507 (see back page) with DIPsw10 set to OFF
- ❑ See Diagram 4 (separate sheet) for detailed connections & combinations.
- ❑ Please take care with the Molex pins when connecting into 8 way connector shell see Diagrams 4 & 5 . Special tool by RSC 2333059.

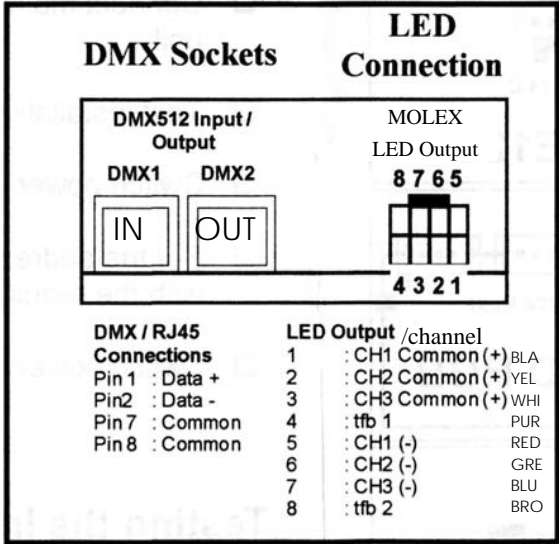

Diagrams 1,2,3,4,5, 6. & mounting brackets. See separate sheets

Max run of extension cable (YY 8*1.5mm sq.) on CL is 110mtr.
If using a 3 way adaptor divide this by 2 or 3 fittings.

DMX Addressing

The address required is set via the DIP switches on the side of the Colour Driver. The most common address is 1, this address must be used with the wall plate (CRE2803) To set the Driver to another address. Remove power. Set the combination of switches that add up to the address required. For example: DMX 11 is 8 + 2 + 1 = 11. See back page.

Please note that if the address DIP switches are changed the Driver must be powered off and then on, to take effect. Each channel requires a DMX address, however the DIP switch only points to the first address which is channel 1. Channel 2 will be the next address DMX+1 and finally, the third channel will be DMX+3.

Special Addresses.....Please see over.....

Colour Driver DMX CRE2801 Key Pad wallplate CRE2803 DMX remote programmer

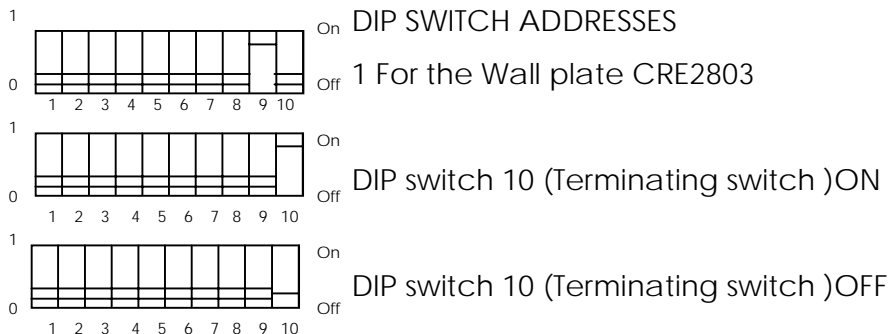

The following are a range of addresses that perform specific driver functions and are provided for testing purposes

Switch	1	2	3	4	5	6	7	8	9
Value	256	128	64	32	16	8	4	2	1

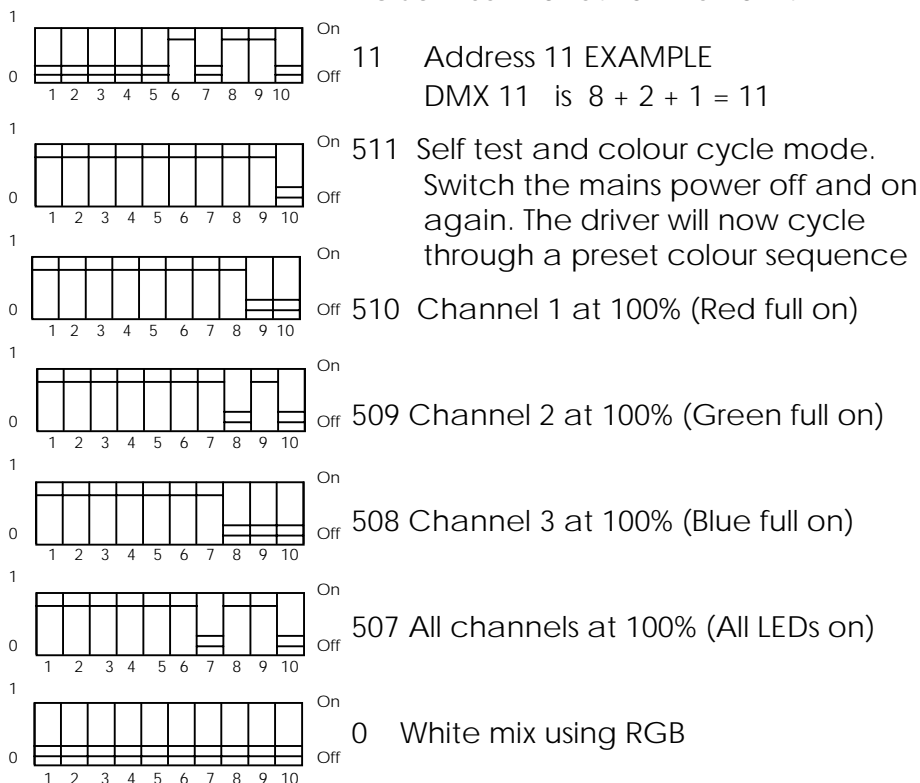

Step by step instructions to install

COLOUR CONTROL 1.Colour DMX driver CRE2801

- Ensure the unit is not powered during installation (i.e. disconnect unit from mains).
- Connect the CL LED unit to the Colour Driver (Molex plug)
- If no DMX control system is being used, set dip switches to desired colour / effect . See back page for switch settings
Dip switch 10 must always be set to off for these displays.
- Connect mains lead (Wieland GST18) to Dmx & mains.Switch on .

COLOUR CONTROL 2 For use with CRE2803+CRE2801 Wallplate keypad control +CLS/CLO LED units

- CRE2803 consists of, Keypad, Smart Card box, mains lead, double ended RJ45 lead, and a single ended RJ45 lead.
- The Keypad fits a standard 25mm deep wall box (by others), connection to the SMART CARD box (grey) is by 8 way terminal block on the keypad , to RJ45 (like a BT plug) .
- Ensure the unit is not powered during installation (i.e. disconnect unit from mains).
- Screw the stripped back cables (colour coded) correctly to the Keypad terminal block.On the Smart card box insert RJ45 into the Keypad socket. Disregard the Smartcard & orange coloured relay sockets. Insert the double ended RJ45 to DMX socket & other plug to DMX IN socket on the first CRE2801 driver.....Continued over.....

Interconnections Between Crescent Colourline RGB Modules and DMX Drivers

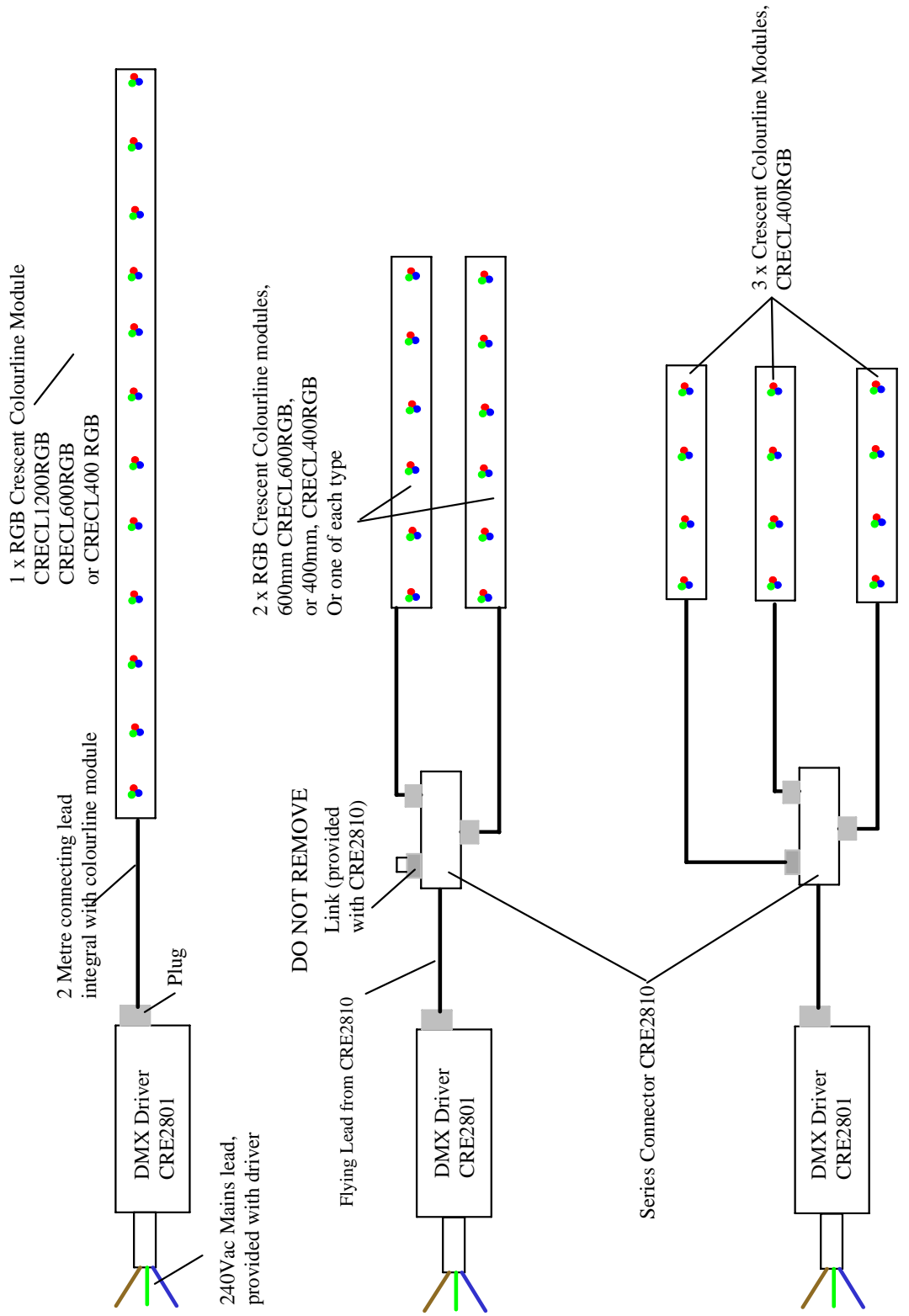
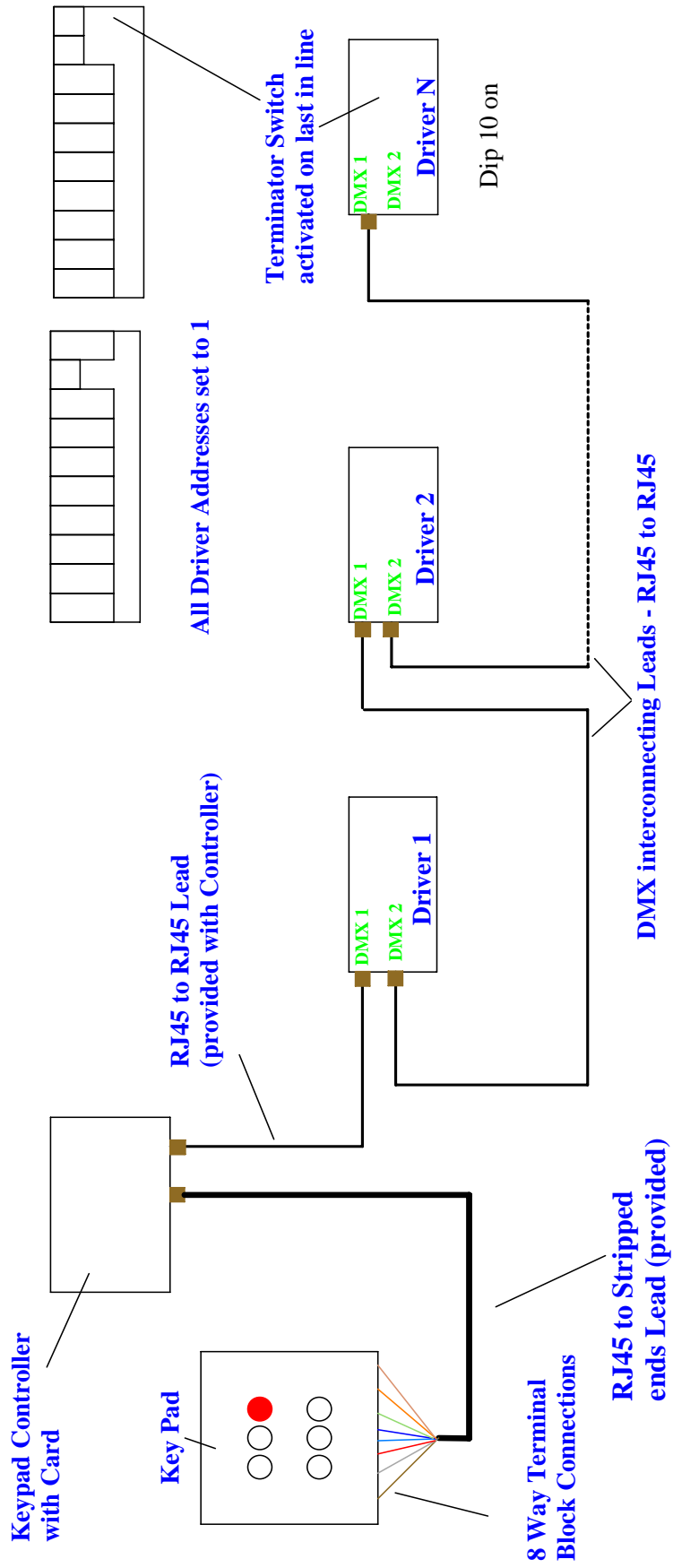

Diagram1

Diagram 2



Key Pad and Controller Interconnections for Colourline RGB Drivers

DMX Programmer eg NJD Merlin

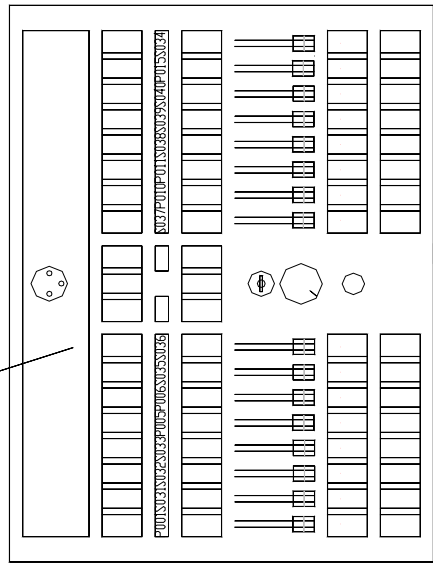

3 or 5 Pin XLR plug depending on controller spec) to RJ45 plug connecting Lead (not supplied by us)

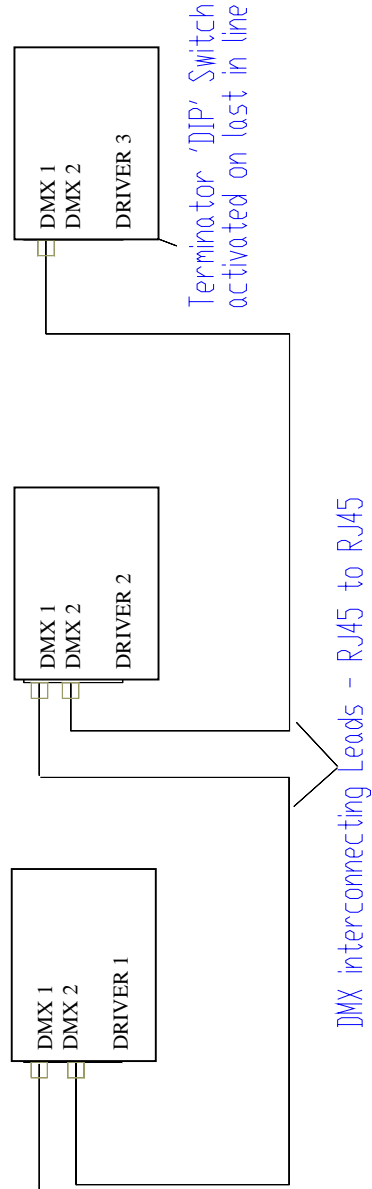
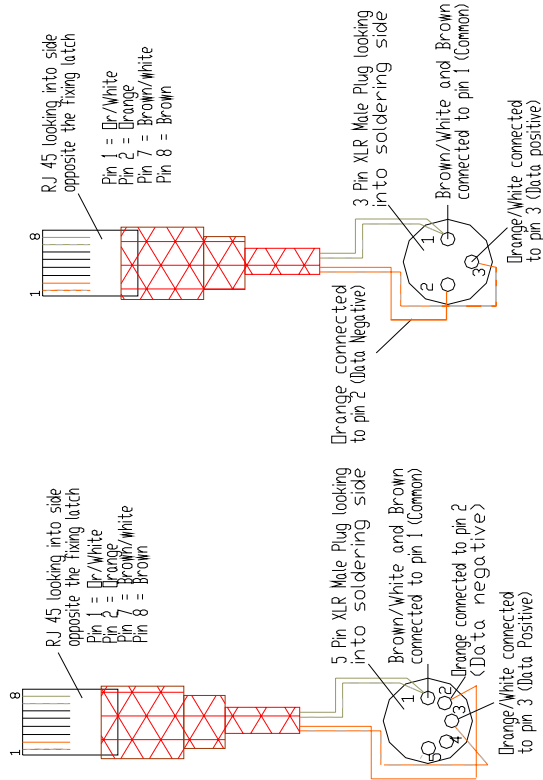

DMX Interconnections for Colourline RGB Drivers

Diagram 3

Diagram 4

Interconnections between Crescent Single Colour CL modules and Drivers.

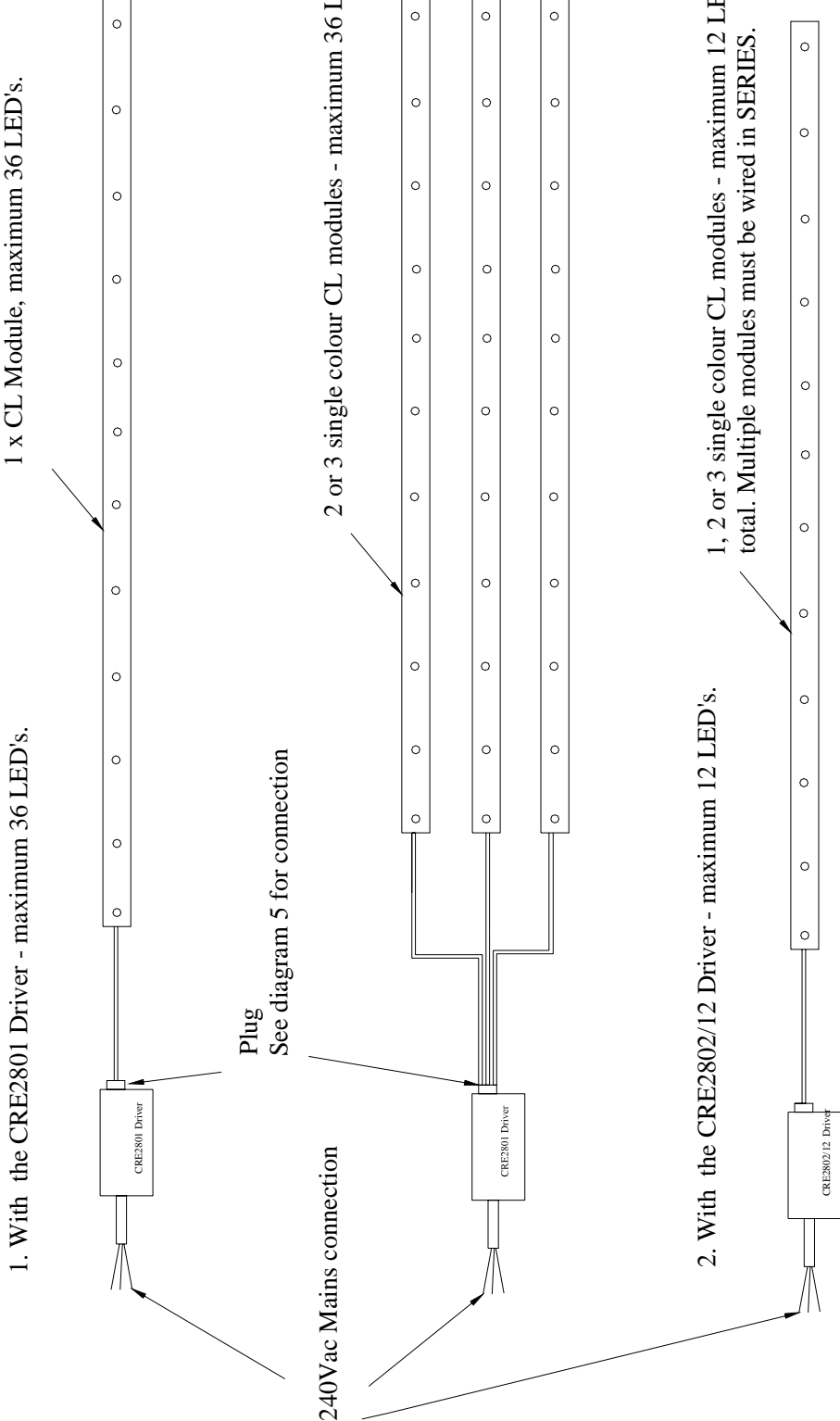
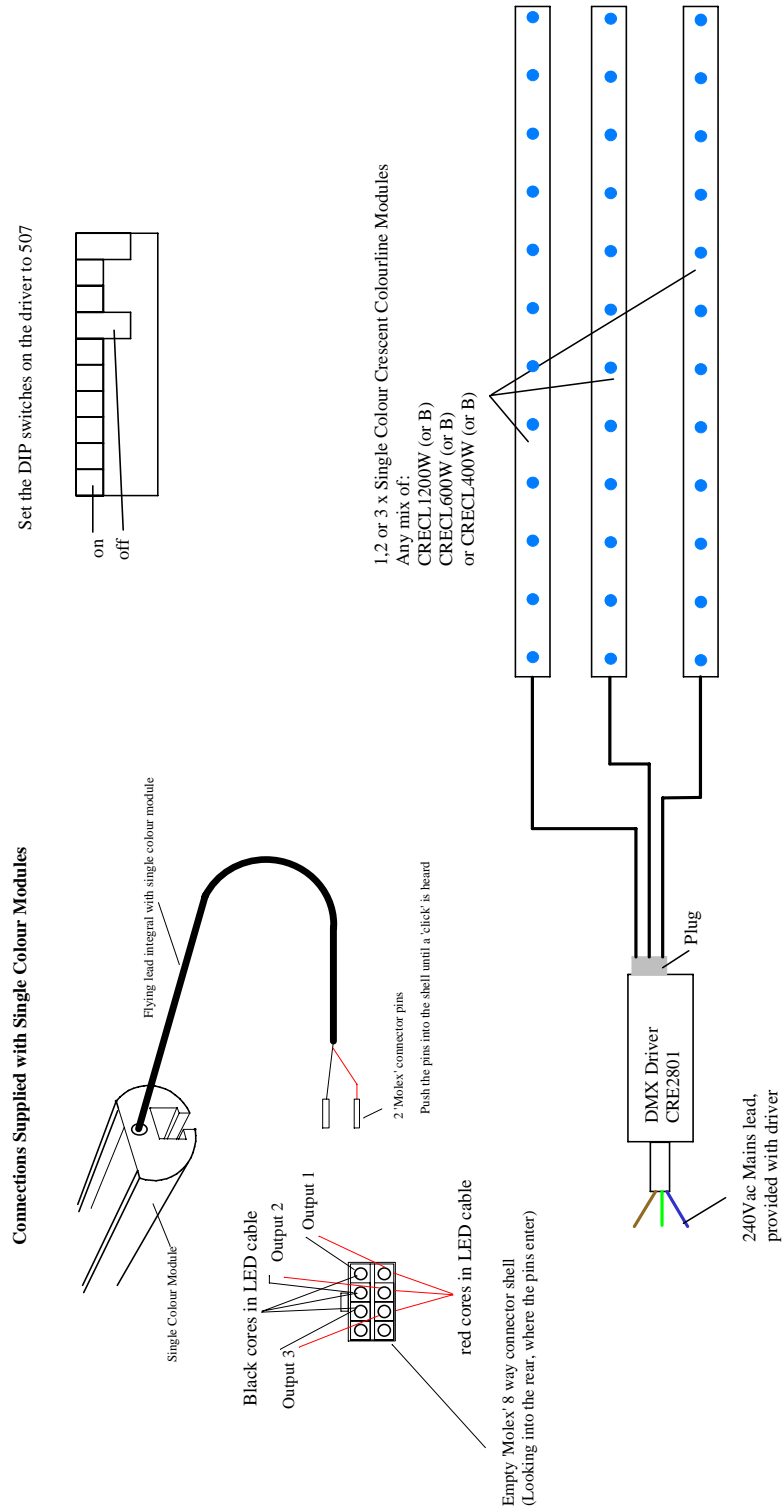

Diagram 5

Interconnections Between Crescent Colourline Single Colour Modules and DMX Driver CRE2801



Molex plug wiring to RGB CL Modules

Diagram 6 June 05

These instructions are only intended for situations where the CL module has not got a 'Molex' plug to fit the CRE2801 DMX driver.

The red wire feeds the red Luxeon, blue to blue and green to green. The return wire is black, white, yellow respectively. This applies to 400 & 600mm lengths. For 1200mm lengths, there is a single black return wire, but still red to red etc.

Technical Note: the positive anode is the common.

The two wires left over are for the temp sensing circuit. For 400 & 600mm lengths they are purple & brown and brown goes in terminal 4 of the Molex socket. For 1200mm lengths, they are yellow & white and white goes in term 4.

See wiring diagrams below:

CLO 400; CLO600; CLS400 & CLS600

4 or 6 Luxeon LEDs per channel

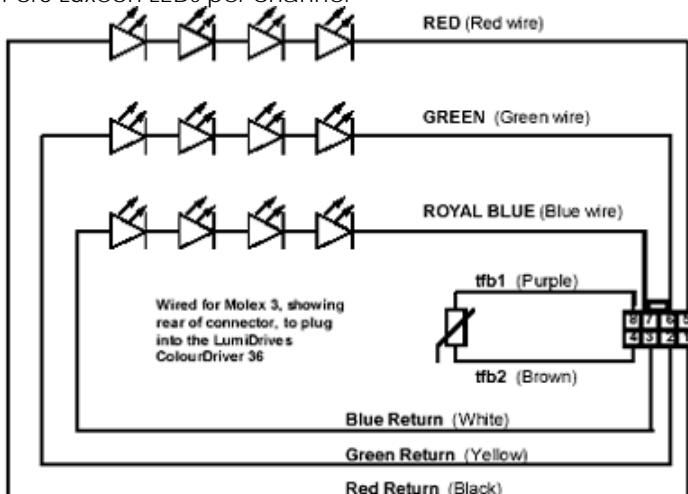

CLO 1200 & CLS1200

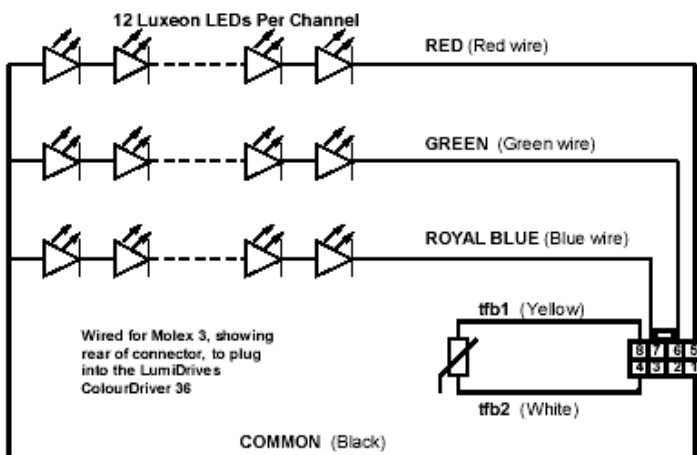

CL Range bracket assembly.

All brackets have angular adjustment - move until the desired effect is achieved.

Visible Bracket.

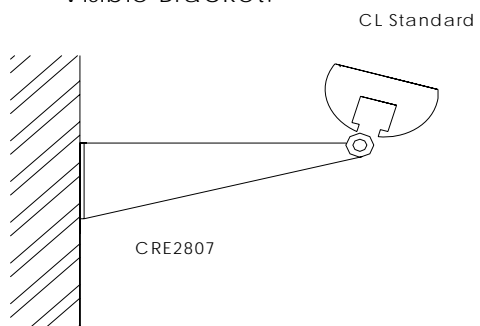

CL Optic

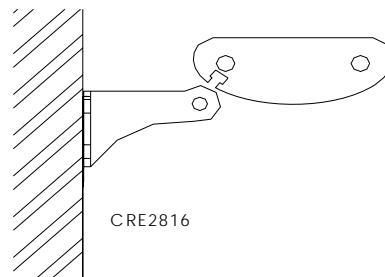

Concealed Bracket.

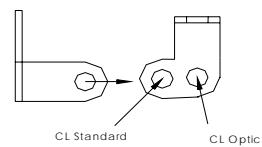
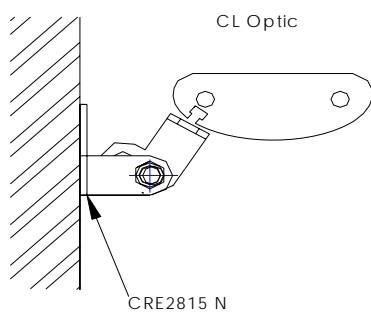

Note the different assembly of the concealed bracket for CL Optic and CL Standard.

CL Standard

