

# Special Product Sheet

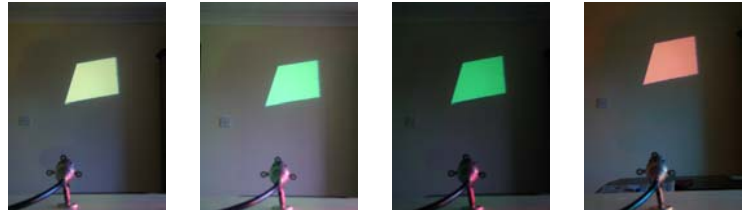

## CRE2385 Framing Spot

<b>Fitting Body:</b>	<b>Aluminium Alloy</b>
<b>Lens :</b>	<b>Double lens system fitted.</b>
<b>Applications :</b>	<b>Pictures, projecting gobos, projecting coloured shapes</b>
<b>Fibre Type :</b>	<b>BPAK 12 to75 recommended.</b>
<b>Finish :</b>	<b>Anodised natural.</b>

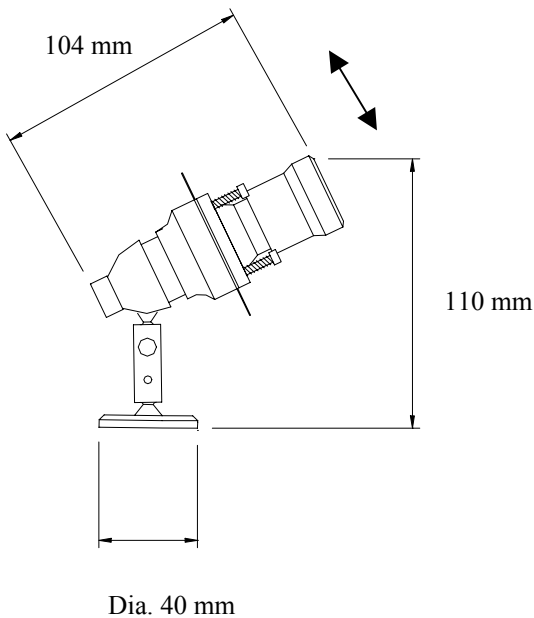

A framing spotlight which is able to illuminate accurately pictures and other square or rectangular shaped items. The precise optics are also able to project gobos and images for effect or identification.

The focusing system is fully adjustable.

Guide price - **£85.50 Contract**      Price is dependant upon quantity and specification.

**Crescent Lighting Limited**, 8 Rivermead, Pipers Lane, Thatcham, Berkshire, RG19 4EP  
Telephone: +44 (0) 1635 878888 Facsimile: +44 (0) 1635 873888  
email address: sales@crescent.co.uk [http:// www.crescent.co.uk](http://www.crescent.co.uk)

**crescent** <sup>®</sup>  
Crescent Lighting Limited  
A Fiberstars Company